

TF 7035 Sleeping Turtle

- Size: 50" L x 43" W x 13" H installed.
Weight: 625 lbs.
Material: Reinforced Concrete.
Color/Surface: Smooth concrete in orange, red, yellow, sand, gray, brown, and light charcoal.
Shell color: Red, yellow, brown and orange.
Reinforcing: 1/2" & 3/8" Dia. steel rebar.
Hardware: 4 - 1/2" Dia. steel inserts.
4 - 1/2" Dia. x 6" anchor bolts provided.
Installation: Anchor to 48" x 45" x 10" minimum cast-on-site footing provided by customer.
See reverse.
Maintenance: Reseal annually or as needed.
Recommendations:
Ages: 3-6.
Child capacity: 3-6.
- Special Note: Manufacturer recommends that the Sleeping Turtle be surrounded by sand or other soft material for safety.

TF 7035 Sleeping Turtle

The Sleeping Turtle

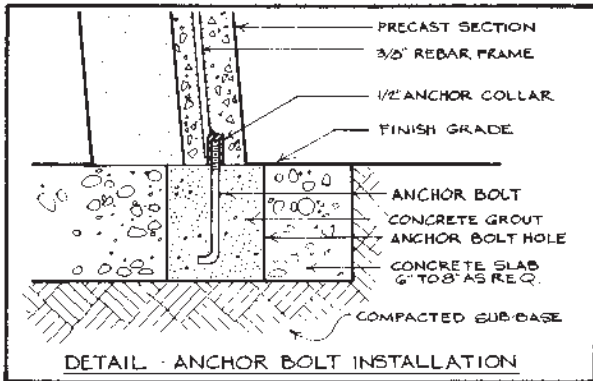
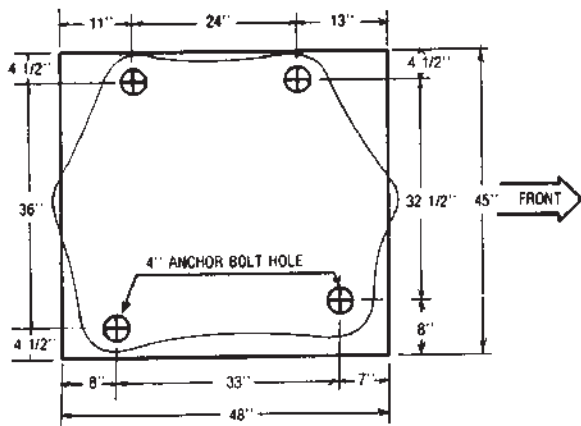
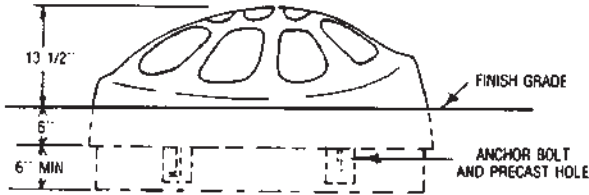

1.1 SUMMARY

- A. Section includes: Furnish Precast Concrete Playground Equipment indicated on drawings or specified herein.

1.2 REFERENCES

- A. American Society for Testing & Materials
 1. ASTM C33
 2. ASTM C150
 3. ASTM C31

1.5 SUBMITTALS

- A. Submit product data, shop drawings and samples.
 1. Product Data: Manufacturer's specifications and technical data edited specifically for proposed system, including the following specific information:
 - a. Detailed specification of construction fabrication.
 - b. Manufacturer's installation instructions
 - c. Maintenance literature
 - d. Product warranty
 2. Shop Drawings: Indicate pertinent dimensions, general construction, component connections anchoring methods, hardware and installation procedures.
 3. Samples as requested by Architect.

1.6 QUALITY ASSURANCE

- A. Qualifications of Manufacturer: Manufacturer to be prequalified by specifier prior to bidding. Failure to comply will result in disqualification of bid. Manufacturer to have at least five years experience in the manufacturer of precast concrete playground equipment field proven for at least five years.

1.10 WARRANTY

Manufacturer shall submit a written warranty for precast products for the period of two (2) years upon acceptance of products.

2.1 MANUFACTURERS

- A. Acceptable manufacturer for Precast Concrete Playground Equipment to be known as:
Wausau Tile, Inc. Terra-Form Division.
PO Box 1520, Wausau, WI 54402-1520.
(800) 388-8728 FAX (715) 355-4627
- B. Clarification Note: Drawings and installation specification are based on manufacturers proprietary literature from Wausau Tile, Inc. Other manufacturers shall comply with minimum levels of material and detailing indicated on drawings or specified herein.
- C. All Precast products for this project shall be of one manufacturer.

2.2 MATERIALS

- A. Portland Cement: ASTM C150 specifications for Portland Cement.
- B. Aggregates: All aggregates to meet ASTM C33 specifications, to be cleaned of foreign matter and properly graded to size.
- C. Coloring: Pigments used shall be inorganic, resistant to alkalinity and used as per manufacturers recommendations.

#