

JACK ATTACHMENT

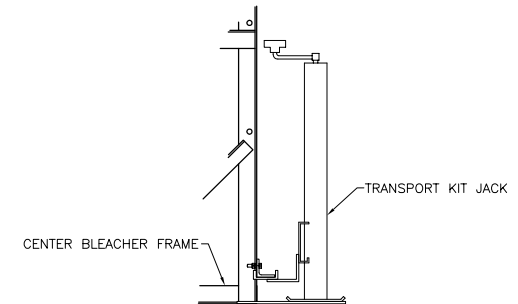

PLACE JACK ON UNDER SIDE OF HORIZONTAL BRACE APPROX. 14"-18" AWAY FROM CENTER FRAME, AS SHOWN. BLEACHER SHOULD ALWAYS BE ON SOLID, LEVEL GROUND, AND BE STABILIZED TO PREVENT MOVEMENT WHEN USING JACK.

NOTE: ILLUSTRATION SHOWN WITH DOUBLE FOOT PLANK, RISER (ROWS 4 & 5), & CHAINLINK GUARDRAIL. PLEASE REFER TO ATTACHED SPECIFICATIONS FOR FEATURES INCLUDED WITH YOUR SPECIFIC BLEACHER.

MARKSTAAR

318 East 8th Street | Post Office Box #189 La Crosse, KS | 67548

Ph: 785-222-2515 | TF: 888-846-2693 | TF Fax: 866-436-7601

