

Front view

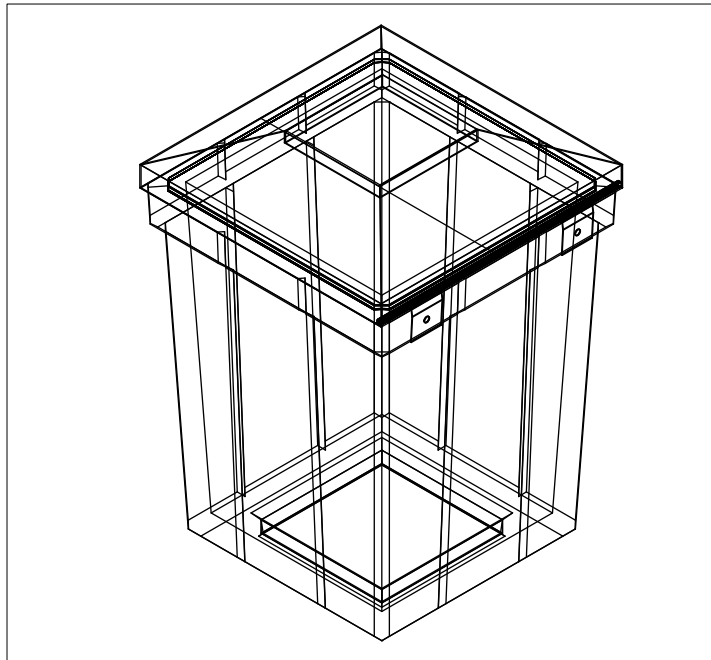

Side View

MODEL: TR40PI
WEIGHT: 350 lbs.
REINFORCING: welded rebar
COLOR: riverrock,
limestone,
quartzite
FINISH: exposed
aggregate
CAPACITY: 40 gallons

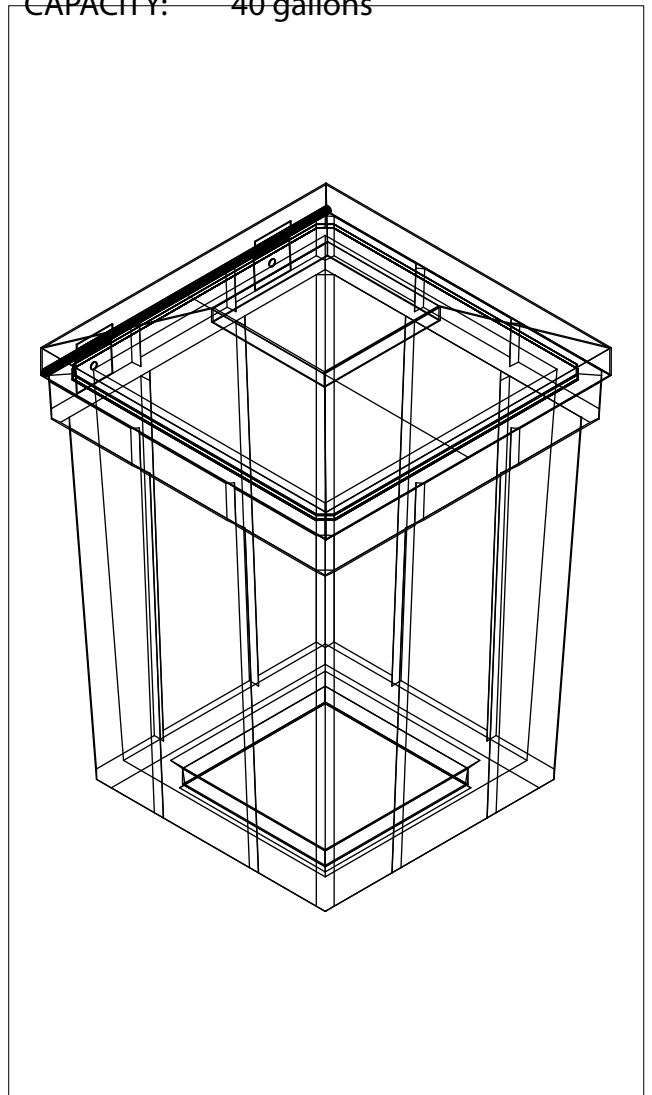

Isometric view



318 East 8th Street | P.O. Box #189 | La Crosse, KS 67548
Ph: 785-222-2515 | TF: 888-846-2693 | Fax: 866-436-7601